



Legatia Pro-Series Component Speakers

Installation & Reference Manual



1240 Oak Industrial Lane
Cumming Georgia 30041
United States

(T) +1 770 888 8200
(F) +1 888 886 4605
hybrid-audio.com

Contents

01

Welcome & Introduction
Pages 4-5

02

Component Specific Information
Pages 6-35
Speaker Attributes, Specifications,
Parameters, and Mechanical Drawings

03

Advanced System Installation
Pages 36-47

04

Warranty
Pages 48-49

**Congratulations
on your Legatia
Pro Component
Speakers
purchase, and
welcome to
the world of
Hybrid Audio
Technologies!**

**Welcome and Introduction
by Scott Buwalda - Founder**

We realize that you have a choice in loudspeakers, and are thrilled that you have chosen the Legatia Pro series component speakers. For more information about Hybrid Audio Technologies, our philosophies regarding high-end mobile audio, to learn more about our lifetime guaranteed value program, and for information about our other products, please visit us at: hybrid-audio.com

Speaker development is our passion! When installed and set-up properly, the Legatia Pro Component Speakers you have purchased will make a remarkable improvement in the sound quality of virtually any mobile audio sound system and give years of superior performance.

With the publication of this manual, it is our goal to assist the “do it yourself” enthusiast and professional installer alike in getting the highest level of performance out of Legatia Pro Component Speakers using straight-forward installation advice.

Thank you, and happy listening!



Legatia Pro Speaker Design

Attributes

The Legatia Pro-series component speakers are electrodynamic drivers that are comprised of a dome diaphragm that is set in motion by a motor system that has both electrical and mechanical components.

The following design tenets are typical of all Legatia Pro-series midrange drivers:

Motor

The motor of the Legatia Pro midrange transducers are paramount to the performance of the drivers, providing for a flat and wide BL curve. The BL curve is flat and extended in all models, yielding exceptional two-way linear excursion, resulting in the Legatia Pro midrange drivers being able to accurately track the input signal. Reduced distortion and greater dynamics are the immediate sonic benefits. The motor of the L3 Pro includes a high-grade NdFeB magnet assembly to improve restorative force, compliance, motor strength, displacement, and power handling, but also to serve a small diameter form-factor. The voice coil fully surrounds the magnet.

Voice Coil

The voice coil diameter of the Legatia Pro range of midrange drivers represents the optimal balance of diameter, power handling, and moving mass. The L3 Pro uses a 50.5mm (2-inch) voice coil. The voice coil diameter serves several key functions: elevated power handling, dissipation of heat (thereby lowering power compression), and maximizing the size of the magnet assembly for enhanced motor compliance. The voice coil used in all Legatia Pro designs are copper-coated high-purity aluminum winding, which is superior to a solid copper winding for heat dissipation, as well as significantly reduced moving mass. The result is an extremely light

weight winding with good power handling and low inductance.

How much amplitude a speaker can reproduce depends on the volume of air it excites without overheating. The volume of air that a speaker excites is determined by the surface area of the dome and the excursion capability of the motor system. X_{max} is defined as the width of the voice coil that extends beyond the front plate, and relates to how far the speaker can move in either direction without appreciable distortion. The Legatia Pro dome midrange designs boast exceptional one-way linear excursion (X_{max}).

Dome

The shape, weight and strength of the Legatia Pro midrange domes relate directly to the extended frequency response of the Legatia Pro range of drivers. The Legatia Pro domes are convex-shaped hybrid fine fabric Japanese cotton diaphragms, described below. A considerable effort was allocated to create a convex diaphragm with exceptional modal damping to have a smooth band-to-band frequency response, applicable in both on- and off-axis applications.

You will find no composite or metal cone materials used in any Legatia Pro midrange driver. Our approach to point-sourcing is to allow the Legatia Pro midrange drivers to effectively play into treble frequencies; having virtually all imaging cues emanating from one set of drivers in an installation ensures stable stereo imaging across the fundamental frequencies which define image placement and definition. As noted above, the Legatia

Pro midrange drivers include a proprietary hybrid Japanese cotton fine fabric diaphragm with extremely low moving mass. The fine fabric dome is widely acknowledged as the best-damping material in the dome geometry format, as it provides the near optimum balance of strength and weight. The fabric dome is critical to tame unwanted dome modes, resonances, and the classic “breakup” associated with most composite materials.

All Legatia Pro designs offer an outstanding extended frequency response; the usable frequency range of the Legatia Pro midrange drivers is at least six full octaves with proper installation, aiming, set-up, and tuning. And because of the employed dome technology which boasts exceptional off-axis response, described above, all Legatia Pro drivers offer exceptional off-axis bandwidth as well, exceeding five octaves for all designs.

Like the L3 Pro, the Legatia L1 Pro tweeter utilizes a fine cloth dome for the ultimate in music reproduction.

Continued on following page...

Legatia Pro Speaker Design

Attributes (Cont'd).

Suspension

All Legatia Pro midrange drivers include a reverse-roll fine treated cloth surround terminated in one piece to the diaphragm, which is highly consistent, and does not suffer the variance of natural rubbers. The surround and diaphragm in concert terminate mechanical vibrations well, having a low stiffness for positive damping of resonances. The surround termination of the dome diaphragm, which acts as an air seal between the dome and the tuned chamber, is the predominant mechanical restoring force of the speaker. Another function of the surround-terminated diaphragm is to absorb dome flexure waves as they are transferred up the diaphragm. You'll also know a Legatia Pro midrange design by its integrated acoustically-transparent grille.

Housing and Tuned Chamber

All Legatia Pro-series products boast a fully machined aluminum body; the body is machined aluminum, not cast aluminum. The dense metal structure of the tweeter and midrange housing helps to reduce resonances within the body of the driver for effective reproduction of extremely low music tones. The dome topology better approximates a true monopole than a similarly-sized cone midrange, especially in the lower one third of its frequency response. Notably, what also makes the L3 Pro a very good approximation of a true

monopole is the fact that the flange/body of the driver is solid machined aluminum, void of interstitial spaces, which terminates resonances well. Hybrid Audio Technologies is likely the only company to produce a super high-end dome midrange, paying attention to the critical function of the housing in modal damping.

In addition to the aluminum body of the Pro-series drivers, all Pro-series drivers include a cast polypropylene tuned and damped chamber at the rear of the motor assembly; the chamber helps to reduce backwave distortion and significantly lower the Pro-series driver's resonance frequency to allow it to be used to play tones near its resonance frequency. A machined aluminum knurled attachment nut at the base of the Pro-series product provides optimized clamping strength to the mounting media, and important feature for terminating modal distortion at the mounting baffle.

Legatia Pro Speaker Design

Application of Thiele/ Small Parameters

Acoustics pioneers Neville Thiele and Richard Small developed a way to predict speaker performance and frequency response. These parameters are known collectively as “Thiele/Small Parameters,” and are divided into physical characteristics and response parameters:

The Physical Characteristics of a speaker are:

Re: The D.C. resistance of the voice coil measured in Ohms.

Sd: The surface area of the speaker’s cone.

BL: The magnetic strength of the motor structure.

Mms: The total moving mass of the speaker including the small amount of air in front of and behind the cone.

Cms: The stiffness of the driver’s suspension

Rms: The losses due to the suspension.

The Thiele/Small Response Parameters are:

Re: The D.C. resistance of the voice coil measured in Ohms.

Sd: The surface area of the speaker.

Fs: The resonant frequency of the speaker.

Qes: The electrical “Q” of the speaker.

Qms: The mechanical “Q” of the speaker.

Qts: The total “Q” of the speaker.

Vas: The volume of air having the same acoustic compliance as the speaker’s suspension.

Enclosure Recommendations

All Legatia Pro-series drivers include a sealed-back tuned chamber, and therefore do not require being mounted in an enclosure. In a typical installation, Legatia Pro midrange and tweeter products should be mounted in a solid mounting baffle to abate resonance (details on baffle recommendations are presented in this manual).

Legatia Pro Speaker Design

L1 Pro Tweeter

Attributes

The Legatia SE L1 Pro is a 58mm (2.3-inch) O.D. “low resonance” wide-bandwidth tweeter driver. Continuing on in the tradition of exceptional tweeter design and manufacturing by Hybrid Audio Technologies, the Legatia Pro L1 is an articulate, detailed, and tonally-correct tweeter in a slightly larger diaphragm than its sibling, the Legatia L1V2. The Pro L1 is a light and transiently fast tweeter in a 25mm body that doesn’t suffer from typical “heaviness” in tonal quality, typically associated with damped, large-diameter dome tweeters; the L1 Pro can be used for the reproduction of treble frequencies in dedicated two-, three-, and four-way front stage systems. The Pro L1 has exceptional polar response, and remains small enough to install in typical locations within a vehicular environment.

At the onset of the Special Edition and Pro-Series Legatia program, we wanted to be sure that the Pro-Series tweeter could be listened to for long listening sessions with no noticeable listener fatigue, and the Pro L1 answers the call. The Pro L1 does an immaculate job of recreating tones well into the vocal midrange frequencies, should the user decide to employ an exceptionally low crossover frequency. The Pro L1 sets the new benchmark for car audio tweeters; it is the best soft-dome car audio tweeter available today, irrespective of price. The L1 Pro is available in two finishes: brushed (natural) aluminum and anodized black.

Dome

The Pro L1 starts with an impregnated fine cloth silk dome diaphragm for a linear, smooth frequency response, with a treated silk surround to damp edge modes and resonances. The Pro L1 is efficient, exhibits low distortion, and has a wide dispersion; the dome is of exceptionally low mass and has

an extremely high power handling with proper filtering. The Pro L1 dome design is much less susceptible to mechanical deformation than other designs, and yet yields a smooth response over the extent of its range.

Motor

The motor assembly is conventional dynamic, with a $\Phi 24.5 \times 3$ H NdFeB neodymium magnet structure to ensure a relatively small footprint size and shallow depth. A perforated grille protects the dome. The Pro L1 boasts a fully machined aluminum body; the body is machined aluminum, not cast aluminum. The dense metal structure of the tweeter housing helps to reduce resonances within the body of the tweeter for effective reproduction of extremely low music tones. Additionally, the Pro L1 has a polypropylene tuned and damped chamber at the rear of the motor assembly; the chamber helps to reduce backwave distortion and significantly lower the tweeter’s resonance frequency to allow it to be used to play tones in the vocal spectrum, if desired. A machined aluminum $\Phi 47.5$ mm knurled attachment nut at the base of the tweeter provides optimized clamping strength to the mounting media.

Mounting Flange and Dimensions

The 58mm wide mounting flange, only 3mm larger than the Legatia L1V2 tweeter, provides a solid-aluminum mounting surface for the tweeter without the necessity of mounting cups or external hardware. The overall dimensions of the driver are very amenable for use in the car audio environment, boasting an exceptional depth of just 30mm (nearly unheard of in a tuned-chamber tweeter).

Terminals Cap and Spring-Loaded Terminals

The L1 Pro includes an extruded polypropylene tuned chamber with integrated high-end

nickel-plated spring-loaded push terminals at the rear of the tweeter’s motor assembly. The spring-loaded terminals give the end-user flexibility in direct connection with large-gauge tinned wiring, without the need for crimp terminals.

Summary

The Legatia SE L1 Pro tweeter is an excellent step-up in performance over the Legatia L1V2 tweeter driver offered in the Stage V Legatia series, and is a bench-mark low-resonance soft-dome tweeter in Hybrid Audio’s complete product offering. Equally at home in two-way configuration paired with a midrange or midbass, or as the dedicated tweeter transducer in a three-way application, the Legatia L1 Pro is an exemplary performer.

L3 Pro on following page...

Legatia Pro Speaker Design

L3 Pro Dome Midrange

History

The Legatia L3 Pro's topology is a departure from the typical cone-type midrange drivers in the same size category as produced by Hybrid Audio Technologies. The L3 Pro was intended to be used in approximately the same fashion as the other cone-type 3-inch midrange devices in the Hybrid Audio product line-up, to give the end-user more choices for a high-end midrange solution to fit a variety of potential system designs and mounting strategy. Naturally, the efficacy of the L3 Pro, as compared to its sibling cone midrange drivers, is its sensitivity and ability to be used without a sealed baffle since the L3 Pro is a tuned rear-chamber midrange.

Attributes

The Legatia L3 Pro is a 99mm (3.9-inch) "small format" wide-bandwidth midrange/full-range driver to compliment both two-way and three-way system designs, where a point-source midrange and/or full-range driver is required. The L3 Pro is only 6mm (0.2-inch) larger than the Stage V Legatia L3V2, and the Stage VI Legatia L3SE, for many potential drop-in replacement options.

Body and Flange

The body and flange of the L3 Pro is a similar design topology and geometry to the L1 Pro tweeter. The body is an extremely high-quality machined aluminum design (machined from a solid block of aircraft-grade 6061 aluminum), and contains a 99mm flange providing for the surface-mounting of the driver via Hybrid Audio Technologies' unique knurled attachment nut technology. The dense

metal structure of the L3 Pro housing helps to reduce resonances within the body of the driver for effective reproduction of extremely low music tones. One main mechanical reason the L3 Pro approximates a true monopole is the fact that the flange/body of the driver is solid machined aluminum, void of interstitial spaces, which terminates resonances well.

The overall dimensions of the driver are very amenable for use in the car audio environment, and in locations typical of the standard "3-inch" and "4-inch" drivers, or in custom locations at the discretion of the end-user, boasting a depth of just 44mm (1.7-inch) (the same depth as the Stage VI Legatia L3SE and only 1mm deeper than its Legatia L3V2 counterpart). The body features an integrated tuned chamber, discussed below, to allow for mounting of the L3 Pro in a simple baffle without worry of separating front and back waves, nor building an enclosure. The rear of the body propagates diaphragm back pressure into the tuned chamber to provide adequate communication to the back of the dome for acoustic suspension and proper operation.

Housing and Tuned Chamber

In addition to the aluminum body of the Pro-series drivers, the L3 Pro includes a cast polypropylene tuned and damped chamber at the rear of the motor assembly; the damped chamber helps to reduce backwave distortion and significantly lower the Pro-series driver's resonance frequency to allow it to be used to play tones near its resonance frequency. The chamber for the L3 Pro is approximately 20 cm³ in internal volume. A machined aluminum knurled attachment nut at the base of the L3 Pro provides optimized clamping strength to the mounting media, and important feature for terminating modal distortion at the mounting baffle.

Motor

The motor of the L3 Pro is paramount to the performance of the driver, providing for a flat and wide BL curve (as a learning note, BL is the equivalent of torque in a car; a car with a flat and constant torque curve provides much better acceleration and performance than a car with a peaky, non-constant torque curve). The BL curve is flat and extended, yielding 4mm of two-way linear excursion, resulting in the L3 Pro being able to accurately track the input signal. Reduced distortion and greater dynamics are the immediate sonic benefits. The motor of the L3 Pro includes an NdFeB magnet to improve restorative force, compliance, motor strength, displacement, and power handling. The magnet assembly fully surrounds the voice coil.

Voice Coil

The voice coil diameter of the L3 Pro is a large 50.5mm (2-inch), which is the proper balance between size and moving mass in super high-end mobile audio midranges/full-range drivers. The voice coil diameter serves several key functions: elevated power handling, dissipation of heat (thereby lowering power compression), and maximizing the size of the magnet assembly for enhanced motor compliance. The voice coil is high-purity aluminum, which is superior to copper for heat dissipation, as well as significantly reduced moving mass. The result is an extremely light weight winding with good power handling and low inductance.

Continued on following page...

Legatia Pro Speaker Design

L3 Pro Dome Midrange

Dome

You will find no composite or metal cone materials used on the L3 Pro, as our approach to point-sourcing is to allow the Legatia Pro midrange driver to effectively play into upper treble frequencies. The Legatia L3 Pro is a dome-type driver consisting of a proprietary Japanese fine cotton hybrid diaphragm with extremely low moving mass. Cotton is widely acknowledged as the best-damping material for dome midrange drivers, as it provides the near optimum balance of strength and weight. The dome has been treated with a water resistant element to accommodate door mounting, or other areas prone to occasional contact with liquid. The dome design offers an exceptional dispersion pattern to make for flexible installation and speaker location. The Legatia L3 Pro has an outstanding extended frequency response; the usable frequency range of this driver exceeds seven complete octaves of usable bandwidth on-axis (250 Hz – 13,000+ Hz). Even off-axis, the L3 Pro faithfully recreates more than five full octaves of information, for the ultimate “small-format” midrange/full-range driver.

Suspension

The surround is an extension of the fine Japanese treated cotton fabric which is highly consistent, and does not suffer the variance of natural rubbers. This surround terminates mechanical vibrations well, having a low stiffness for positive damping of resonances.

Terminals

The Legatia L3 Pro comes equipped with heavy-duty nickel-plated spring-loaded push terminals for both positive and negative. The terminals optimize contact, and give the end user flexibility in tinned wire or binding post terminations

Summary

The Legatia L3 Pro is the world’s finest multi-purpose super high-end dome midrange speaker driver. Mechanical and electrical parameters are amenable to a variety of different installations and speaker locations. This driver is intended to be used in a variety of installation protocols and arrangements. The size of the L3 Pro allows it to be mounted in typical “3-inch” and “4-inch” midrange locations within a vehicle, or in custom locations at the discretion of the end-user, even in areas where there may not be adequate airspace behind the driver.

At home in virtually any arrangement, the L3 Pro is Hybrid Audio Technologies’ Legatia Pro high-end small-format midrange offering, boasting exceptional performance and a design philosophy that goes hand in hand with true high-fidelity playback.

Legatia Pro Speaker Design

Although the Legatia L2x is listed in the Stage V Legatia series, it has multiple complimentary uses for Legatia Pro products as well, given the complimentary crossover topology and use of low-tolerance, asymmetrically-aligned componentry and lack of board-mounted equalization

L2x Two-Way Passive Crossover

The Legatia L2x topology is an enhanced Stage V version of the Stage IV Clarus C2x passive crossover network. It's no secret that Hybrid Audio Technologies highly recommends the use of active crossovers that are set-up and adjusted by an industry specialist, such as a master tuner, or a highly-qualified car audio shop installer (please read any number of White Papers on the subject of passive crossovers available at: hybrid-audio.com/downloads). In some cases, however, using active crossovers is not a viable option, so we designed and manufactured the Legatia L2x to allow for easy Legatia installations, especially when multiple amplifier channels and/or adequate active crossover processing was not available in the car audio installation.

The L2x can be used for two-way passively crossed-over systems, or used as the two-way dividing network for midrange and treble drivers in a "quasi-active" three-way (six speaker) system, where the midbass is actively crossed-over at the amplifier. The L2x is based loosely off of the Clarus C2x crossover, with key enhancements, including the option for vertical bi-wiring, as well as an enhanced filter set using low-tolerance, super high-quality parts.

Key Issues in Passive Crossover Design

Before highlighting the L2x's design attributes, there are certain key issues in passive crossover design that the end-user should be aware of. For years, vocal manufacturers have coerced the consumer into believing that capacitors, coils, and resistors are not only desirable, but are a requirement. One notable "high-end" speaker manufacturer boasts that they spend "months" working on crossover designs to 'enhance' their speakers. To 'enhance'

means to add considerable filtering to fix speaker response anomalies, aka poor speaker designs.

Our speaker design philosophy is to spend the time and resources necessary to make the speakers exceptional in the design phase, and then use simpleton filtering to protect only for thermal protection at resonance and provide the desired frequency response filtering via crossovers. It is our philosophy that the passive crossover should not contain any level of equalization; none of our designs, in any series, use crossovers that contain any form of equalization beyond simple tweeter attenuation. We believe in making the speaker great, not trying to fix a poor speaker with filtering and attenuation. There's no crossover in the world that can make a poorly-designed speaker sound good. This is why there's a relatively simple, high-quality crossover topology employed on the Legatia L2x crossover, with no additional board-mounted equalization. And this is also why we implore you to use our world-class speaker systems in concert with the L2x.

Attributes

The Legatia L2x is a bi-amplified two-way passive crossover for use with virtually any midrange, midbass and tweeter pairing Hybrid Audio manufactures. The following are the L2x's design attributes:

Filter Set

The L2x is a bi-wired two-way passive crossover that has the following filters:

Lowpass (midrange): 5,700 Hz at 12 dB/octave Linkwitz Riley

Highpass (treble): 5,200 Hz at 12 dB/octave Linkwitz Riley

The only filtering on the board is mentioned above, and in essence are elementary highpass and

lowpass filters common in any two-way crossover design. As noted above, there is no board-mounted equalization specific to one brand or type of midrange or tweeter, or common of competitor's designs where equalization correction (filtering) is added. The L2x can be used with any number of drivers we produce.

The L2x passive crossover networks incorporate super high quality and low tolerance metalized polypropylene film capacitors, air-core inductors, and low tolerance non-inductive resistors. No output level switches were used in the passive crossover design because switches add a resistive effect and are typically of extremely low quality. Additionally, "jumper pins" add an unnecessary pair of splices in the signal path to the tweeter, and were not included in our design either. Rather, all tweeter level adjustments are done on the board level with dedicated non-inductive resistors; tweeter attenuation is accomplished by selecting the appropriate output (-3 dB, 0 dB, or +3 dB) on the passive crossover circuit board. The components selected are complimentary and ensure no appreciable signal degradation between the input and output side of the crossovers. Likewise, the capacitors and inductors are arranged on the board to reduce the coupling between circuits and electromagnetic interference by basic physical separation, while still keeping the footprint size of the circuit board small. Finally, the use of 12 dB/octave filters on both low pass and high pass minimizes phase-related distortion typical of crossovers with mismatched orders, and ensures relative phase-coherency.

L2x Cont'd on following page...

Legatia Pro Speaker Design

Although the Legatia L2x is listed in the Stage V Legatia series, it has multiple complimentary uses for Legatia Pro products as well, given the complimentary crossover topology and use of low-tolerance, asymmetrically-aligned componentry and lack of board-mounted equalization

L2x Two-Way Passive Crossover

Connection

The L2x has convenient spring-loaded terminals for wire connection. Bare wire can be twisted tightly and inserted into the spring-loaded terminal; however Hybrid Audio recommends that the wire be tinned with solder to avoid oxidation, fraying, and to promote a better connection. The following is the connection nomenclature on the L2x, from left to right on the circuit board:

- +WF Woofer positive input from amplifier
- IN - Woofer negative input from amplifier
- +WF Woofer positive output to Hybrid Audio Technologies midbass or midrange positive terminal
- OUT - Woofer negative output to Hybrid Audio Technologies midbass or midrange negative terminal
- + TW Tweeter positive input from amplifier
- IN - Tweeter negative input from amplifier
- HI + Tweeter positive output to Hybrid Audio Technologies tweeter positive terminal, +3 dB setting
- MID + Tweeter positive output to Hybrid Audio Technologies tweeter positive terminal, 0 dB setting
- LOW + Tweeter positive output to Hybrid Audio Technologies tweeter positive terminal, -3 dB setting
- TW - Tweeter negative output to Hybrid Audio Technologies tweeter negative terminal

NOTE: the L2x is a bi-wired crossover, meaning the crossover has two sets of inputs for use with two two-channel amplifiers or a four-channel amplifier. If you wish to not use two two-channel amplifiers or a four-channel amplifier, and use only one two-channel amplifier instead, simply “bridge” the connections between + WF and + TW and IN – and IN – with two short strands of insulated wire.

Once all speakers are installed, you will need to do a brief listening test with high-quality music that you are intimately familiar with to determine which tweeter attenuation you desire. Be sure that all equalization, bass, and treble levels are defeated or set to “zero” on the source unit before evaluating the intensity of the tweeters with respect to your midrange/midbass level and your listening taste. Note also, after approximately 25 hours, the speakers will begin to “break in”, like any mechanical component, and intensities may need to be re-adjusted again. In other words, the midbass need to be broken in with typical play-time before final tweeter attenuation is set. You may find that after break-in, the tweeter intensity will need to be re-adjusted.

Mounting

Choose your L2x mounting location carefully. The L2x contains parts that are susceptible to damage through repeated shock, moisture, and electromagnetic interference. For example, it is advisable to install the passive crossovers inside the passenger compartment versus the door, since the door is exposed to repeated opening and closing “shock” which may damage the delicate passive crossover components, or cause soldered joints to break over time. Likewise, moisture may be present in a door installation. Finally, if you are mounting the passive crossovers in the kick panels or dashboard, be sure to keep the networks away from any noise-inducing device within the vehicle, such as factory ECU’s, auto transmission control ECU’s, BCM’s, alternator

field/stator wiring, and numerous other devices. Readers note: be mindful of the location of throttle, brake, and clutch pedals when you are selecting a mounting location and where to route the speaker wiring.

If the only option for crossover mounting is in the door, it would typically be prudent to install the passive crossovers immediately adjacent to the midbass location to keep speaker wiring and connections short and allow access to the OEM wiring, if it is used, without having to extend it and creating an additional resistive splice in the wire. If you must install the L2x in the door, DO NOT MOUNT THE CROSSOVER INSIDE THE DOOR CAVITY! Rather, install the networks on the same mounting plane as the midbass, toward the passenger compartment, and behind the OEM door panel/skin, so as to not expose the delicate electronic parts contained within to moisture inside the door cavity. Once an adequate spot for mounting the L2x is found, securely mount the crossover networks using the supplied screws. Before any cutting, drilling, or insertion of screws, check the clearance of the panel from behind to verify that you won’t be damaging existing wiring, window or door lock motors, window tracks and the windows themselves, and etc.

Summary

The Legatia L2x is an exceptional-quality two-way passive crossover device that can be used with any Hybrid Audio speaker system to accommodate any number of different bespoke system designs. At home in virtually any arrangement, the L2x is Hybrid Audio Stage V high-end two-way passive crossover, boasting exceptional performance and a design philosophy that goes hand in hand with true high-fidelity playback.

L3x on following page...

Legatia Pro Speaker Design

Although the Legatia L2x is listed in the Stage V Legatia series, it has multiple complimentary uses for Legatia Pro products as well, given the complimentary crossover topology and use of low-tolerance, asymmetrically-aligned componentry and lack of board-mounted equalization

L3x Three-Way Passive Crossover

History

The Legatia L3x topology is loosely based off of the Legatia L2x crossover topology. It's no secret that Hybrid Audio Technologies highly recommends the use of active crossovers that are set-up and adjusted by an industry specialist, such as a master tuner, or a highly-qualified car audio shop installer (please read any number of White Papers on the subject of passive crossovers on the www.hybrid-audio.com/downloads.htm web page). In some cases, however, using active crossovers is not a viable option, so we designed and manufactured the Legatia L3x to allow for easy Legatia installations, especially when multiple amplifier channels and/or adequate active crossover processing was not available in the car audio installation.

The L3x can be used for virtually any Legatia three-way passively crossed-over systems, or used in conjunction with other Hybrid Audio products to create a truly "bespoke" three-way system.

Key Issues in Passive Crossover Design

Before highlighting the L3x's design attributes, there are certain key issues in passive crossover design that the end-user should be aware of. For years, vocal manufacturers have coerced the consumer into believing that capacitors, coils, and resistors are not only desirable, but are a requirement. One notable "high-end" speaker manufacturer boasts that they spend "months" working on crossover designs to 'enhance' their speakers. To 'enhance' means to add considerable filtering to fix speaker response anomalies, aka poor speaker designs.

Our speaker design philosophy is to spend the time and resources necessary to make the speakers exceptional in the design phase, and then use simpleton filtering to protect only for thermal protection at resonance and provide the desired frequency response. It is our philosophy that the passive crossover should not contain any level of equalization; none of our designs, in any series, use crossovers that contain any form of equalization beyond simple tweeter attenuation. We believe in making the speaker great, not trying to fix a poor speaker with filtering and attenuation. There's no crossover in the world that can make a poorly-designed speaker sound good. This is why there's a relatively simpleton, high-quality crossover topology employed on the Legatia L3x crossover, with no additional board-mounted equalization. And this is also why we implore you to use our world-class speaker systems in concert with the L3x.

Attributes

The Legatia L3x is a bi-amplified three-way passive crossover for use with virtually any midrange, midbass and tweeter pairing Hybrid Audio manufactures. The following are the L3x's design attributes:

Filter Set

The L3x is a bi-wired three-way passive crossover that has the following filters:

Lowpass (midbass): 300 Hz at 12 dB/octave Linkwitz Riley

Bandpass (midrange): 300 Hz to 6,000 Hz at 12 dB/octave Linkwitz Riley

Highpass (treble): 6,000 Hz at 12 dB/octave Linkwitz Riley

The only filtering on the board is mentioned above, and in essence are elementary highpass, bandpass, and lowpass filters common in any three-way

crossover design. As noted above, there is no board-mounted equalization specific to one brand or type of midrange or tweeter, or common of competitor's designs where equalization correction (filtering) is added. The L3x can be used with any number of drivers we produce.

The L3x passive crossover networks incorporate asymmetrically arranged super high quality and low tolerance metalized polypropylene film capacitors, air-core inductors, and low tolerance non-inductive resistors. Even the massive lowpass and bandpass capacitors are super high-quality polypropylene capacitors, nearly unheard of by today's standards. No output level switches were used in the passive crossover design because switches add a resistive effect and are typically of extremely low quality. Additionally, "jumper pins" add an unnecessary pair of splices in the signal path to the tweeter, and were not included in our design either. Rather, all tweeter level adjustments are done on the board level with dedicated non-inductive resistors; tweeter attenuation is accomplished by selecting the appropriate output (-3 dB, 0 dB, or +3 dB) on the passive crossover circuit board. Likewise, midrange attenuation is accomplished by selecting the appropriate output (0 dB or -3 dB). The components selected are complimentary and ensure no appreciable signal degradation between the input and output side of the crossovers. Likewise, the capacitors and inductors are arranged on the board to reduce the coupling between circuits and electromagnetic interference by basic physical separation, while still keeping the footprint size of the circuit board small. Finally, the use of 12 dB/octave filters on both low pass and high pass minimizes phase-related distortion typical of crossovers with mismatched orders, and ensures relative phase-coherency.

L3x Cont'd on following page...

Legatia Pro Speaker Design

Although the Legatia L2x is listed in the Stage V Legatia series, it has multiple complimentary uses for Legatia Pro products as well, given the complimentary crossover topology and use of low-tolerance, asymmetrically-aligned componentry and lack of board-mounted equalization

L3x Three-Way Passive Crossover

Connection

The L3x has convenient spring-loaded terminals for wire connection. Bare wire can be twisted tightly and inserted into the spring-loaded terminal; however Hybrid Audio recommends that the wire be tinned with solder to avoid oxidation, fraying, and to promote a better connection. The following is the connection nomenclature on the L3x, from left to right on the circuit board:

- +WF Woofer positive input from amplifier
- IN - Woofer negative input from amplifier
- +WF Woofer positive output to Hybrid Audio Technologies midbass or midrange positive terminal
- OUT - Woofer negative output to Hybrid Audio Technologies midbass or midrange negative terminal
- +M/TW Midrange and tweeter positive input from amplifier
- IN - Midrange and tweeter negative input from amplifier
- +M/H Midrange positive output to Hybrid Audio Technologies midrange positive terminal, 0 dB setting
- +M/L Midrange positive output to Hybrid Audio Technologies midrange positive terminal, -3 dB setting
- +T/H Tweeter positive output to Hybrid Audio Technologies tweeter positive terminal, +3 dB setting
- +T/M Tweeter positive output to Hybrid Audio Technologies tweeter positive terminal, 0 dB setting
- +T/L Tweeter positive output to Hybrid Audio Technologies tweeter positive terminal, -3 dB setting
- TW - Tweeter negative output to Hybrid Audio Technologies tweeter negative terminal

NOTE: the L3x is a bi-wired crossover, meaning the crossover has two sets of inputs for use with two two-channel amplifiers or a four-channel amplifier. If you wish to not use two two-channel amplifiers or a four-channel amplifier, and use only one two-channel amplifier instead, simply “bridge” the connections between + WF and + M/T and IN – and IN – with two short strands of insulated wire.

Once all speakers are installed, you will need to do a brief listening test with CD-quality music that you are intimately familiar with to determine which midrange and/or tweeter attenuation you desire. Be sure that all equalization, bass, and treble levels are defeated or set to “zero” on the source unit before evaluating the intensity of the tweeters with respect to your midrange/midbass level and your listening taste. Note also, after approximately 25 hours, the speakers will begin to “break in”, like any mechanical component, and intensities may need to be re-adjusted again. In other words, the midbass and midrange need to be broken in with typical play-time before final midrange and tweeter attenuation is set. You may find that after break-in, the midrange and/or tweeter intensity will need to be re-adjusted.

Mounting

Choose your L3x mounting location carefully. The L3x contains parts that are susceptible to damage through repeated shock, moisture, and electromagnetic interference. For example, it is advisable to install the passive crossovers inside the passenger compartment versus the door, since the door is exposed to repeated opening and closing “shock” which may damage the delicate passive crossover components, or cause soldered joints to break over time. Likewise, moisture may be present in a door installation. Finally, if you are mounting the passive crossovers in the kick panels or dashboard, be sure to keep the networks away from any noise-inducing device within the vehicle, such as factory ECU’s,

auto transmission control ECU’s, BCM’s, alternator field/stator wiring, and numerous other devices. Readers note: be mindful of the location of throttle, brake, and clutch pedals when you are selecting a mounting location and where to route the speaker wiring.

If the only option for crossover mounting is in the door, it would typically be prudent to install the passive crossovers immediately adjacent to the midbass location to keep speaker wiring and connections short and allow access to the OEM wiring, if it is used, without having to extend it and creating an additional resistive splice in the wire. If you must install the L3x in the door, DO NOT MOUNT THE CROSSOVER INSIDE THE DOOR CAVITY! Rather, install the networks on the same mounting plane as the midbass, toward the passenger compartment, and behind the OEM door panel/skin, so as to not expose the delicate electronic parts contained within to moisture inside the door cavity.

Once an adequate spot for mounting the L3x is found, securely mount the crossover networks using the supplied screws. Before any cutting, drilling, or insertion of screws, check the clearance of the panel from behind to verify that you won’t be damaging existing wiring, window or door lock motors, window tracks and the windows themselves, and etc.

Summary

The Legatia L3x is an exceptional-quality three-way passive crossover device that can be used with any Hybrid Audio speaker system to accommodate any number of different bespoke system designs. At home in virtually any arrangement, the L3x is Hybrid Audio Stage V high-end three-way passive crossover, boasting exceptional performance and a design philosophy that goes hand in hand with true high-fidelity playback.

Legatia Pro Component Speakers

Specifications & Parameters

	L1 Pro	L3 Pro
Overall Diameter	Φ58 mm	Φ99 mm
Mounting Depth	30 mm	44 mm
Mounting Hole		φ85 mm
Mounting Methodology	Surface-mount tweeter with standard-pitch M47.5 X 8mm thick knurled thread aluminum adapter to secure the tweeter body from the rear.	Surface-mount midrange with standard-pitch M99 X 4mm thick knurled thread aluminum adapter to secure the mid-range body from the rear.
Construction	Solid machined aluminum with integrated polypropylene rear cap and push terminals .	Solid machined aluminum with integrated polypropylene rear cap and push terminals.
Distortion	<5% max at rated power input, no crossover	<5% max at rated power input, no crossover
Magnet Diameter and Construction	Φ24.5 × 3 H NdFeB	Φ49.5 X 5mm H NdFeB
Recommended Minimum Crossover Frequency	2,000 Hz at 24 dB/octave highpass	400 Hz at 24 dB/octave highpass
Pnom Rated Power Input (No Crossover)	20 watts (AES Standard)	30 watts (AES Standard)
Pmax Rated Power Input (No Crossover)	40 watts (AES Standard)	60 watts (AES Standard)
Pmax (With Recommended Minimum Crossover)	100 watts	80 watts
Resonance Frequency (Fs)	700 Hz	249 Hz
Frequency Range	700 Hz – 32,000 Hz, +/- 3 dB	249 Hz – 13,000 Hz, +/- 3 dB
Sensitivity	93.5 dB at 2.83V/1meter	94 dB at 2.83V/1meter
Impedance	4Ω	4 Ω
DC Resistance	3.6Ω	3.0 Ω
Voice Coil Diameter	25.5 mm (1-inch)	50.5 mm (2-inch)
Qms	2.842	2.349
Qes	2.113	0.657
Qts	1.212	0.513
Krm	175.5 nΩ	
Erm	1.325	
Kxm	14.545 μH	
Exm	1.004	

Legatia L1 Pro Mechanical Drawing

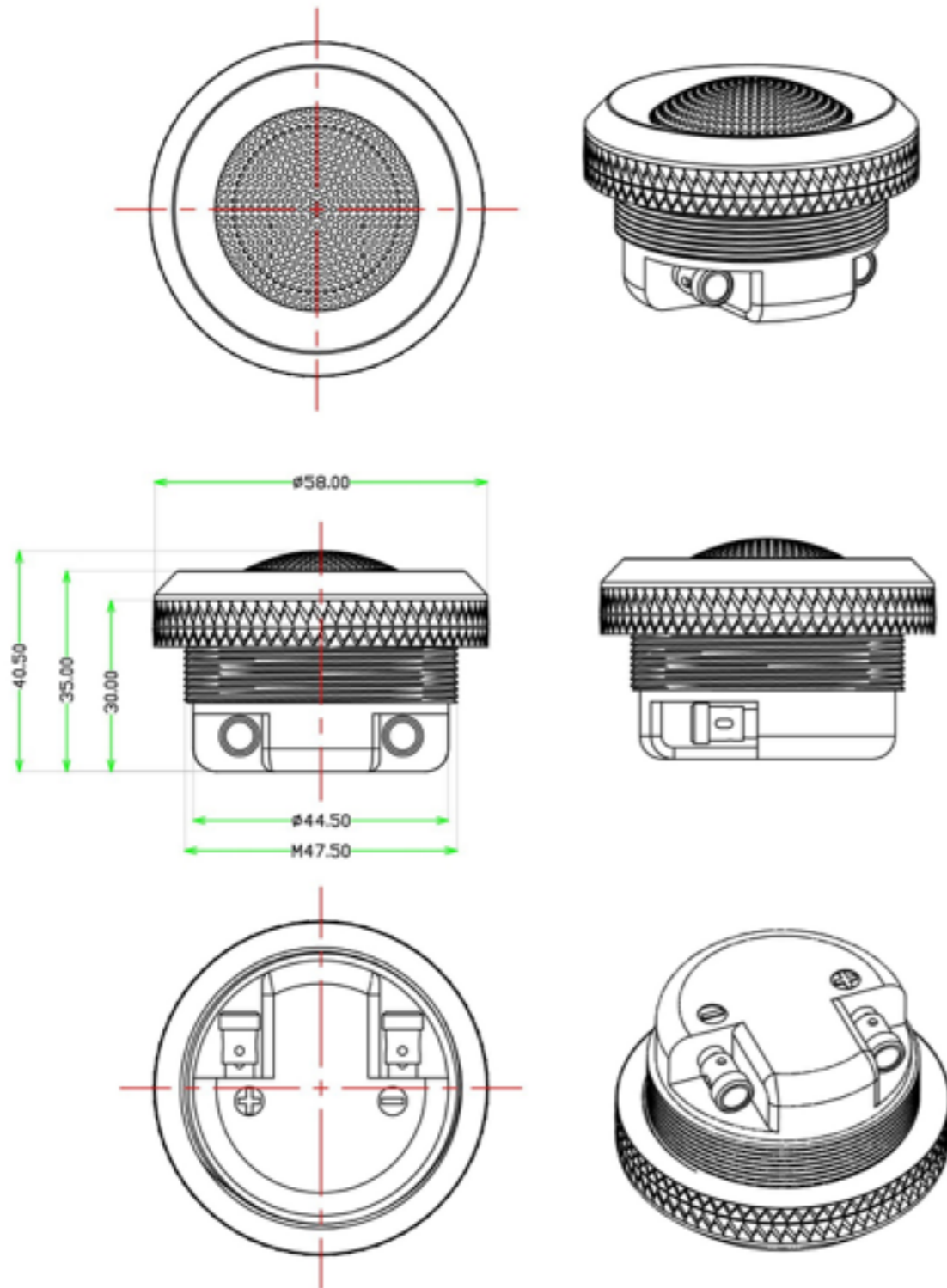

Legatia L3 Pro Mechanical Drawing

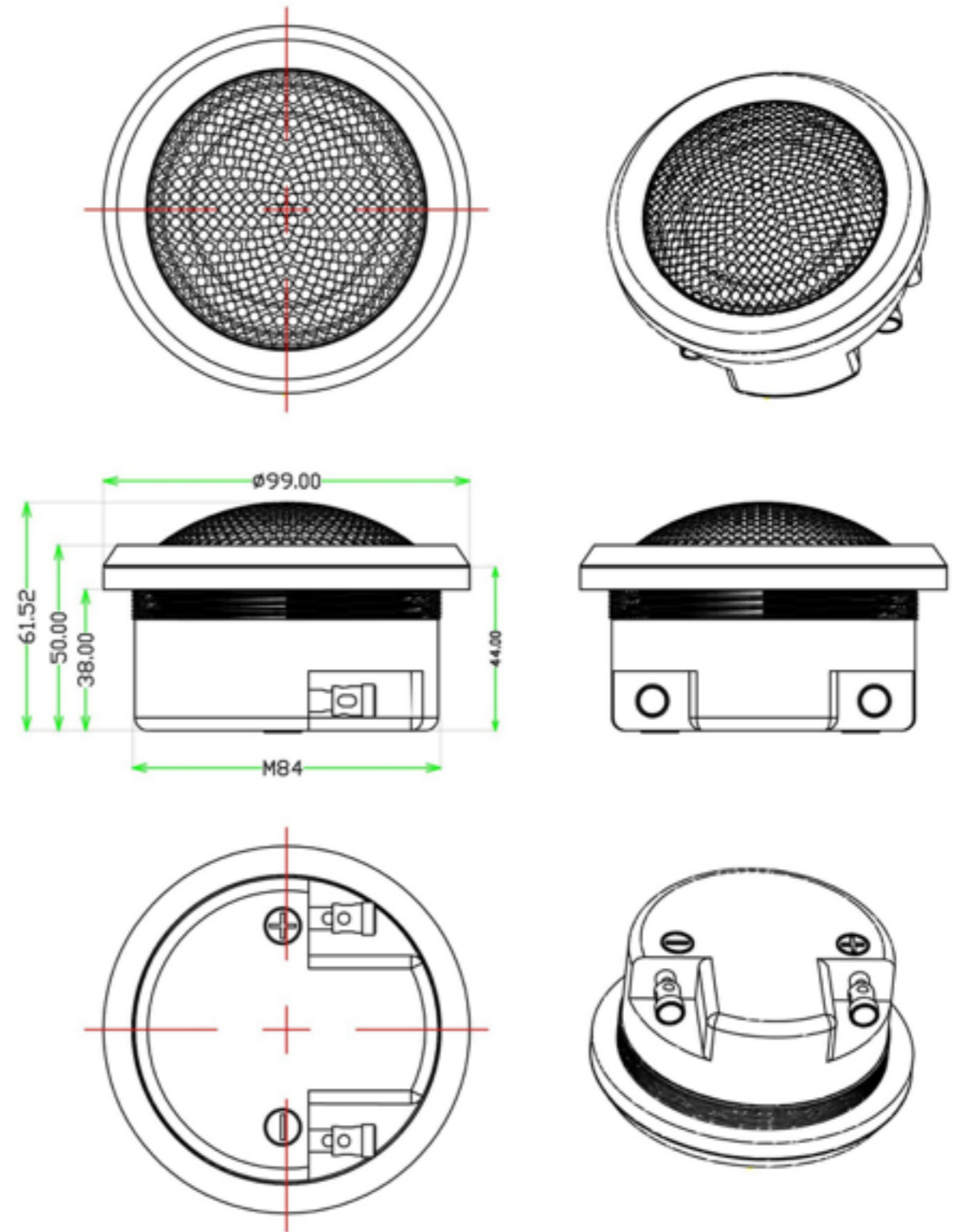

Legatia L2x Mechanical Drawing

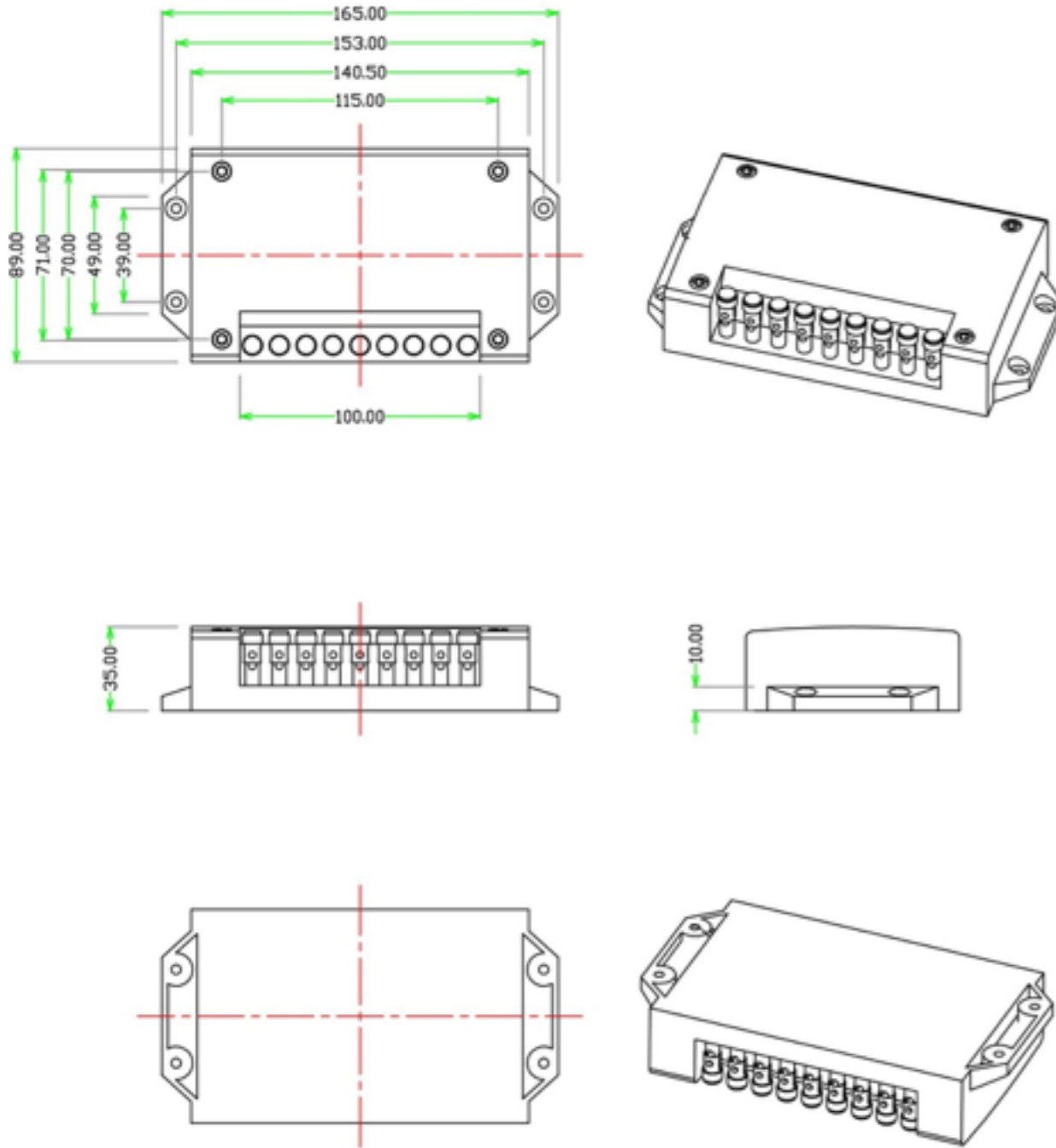

Legatia L3x Mechanical Drawing

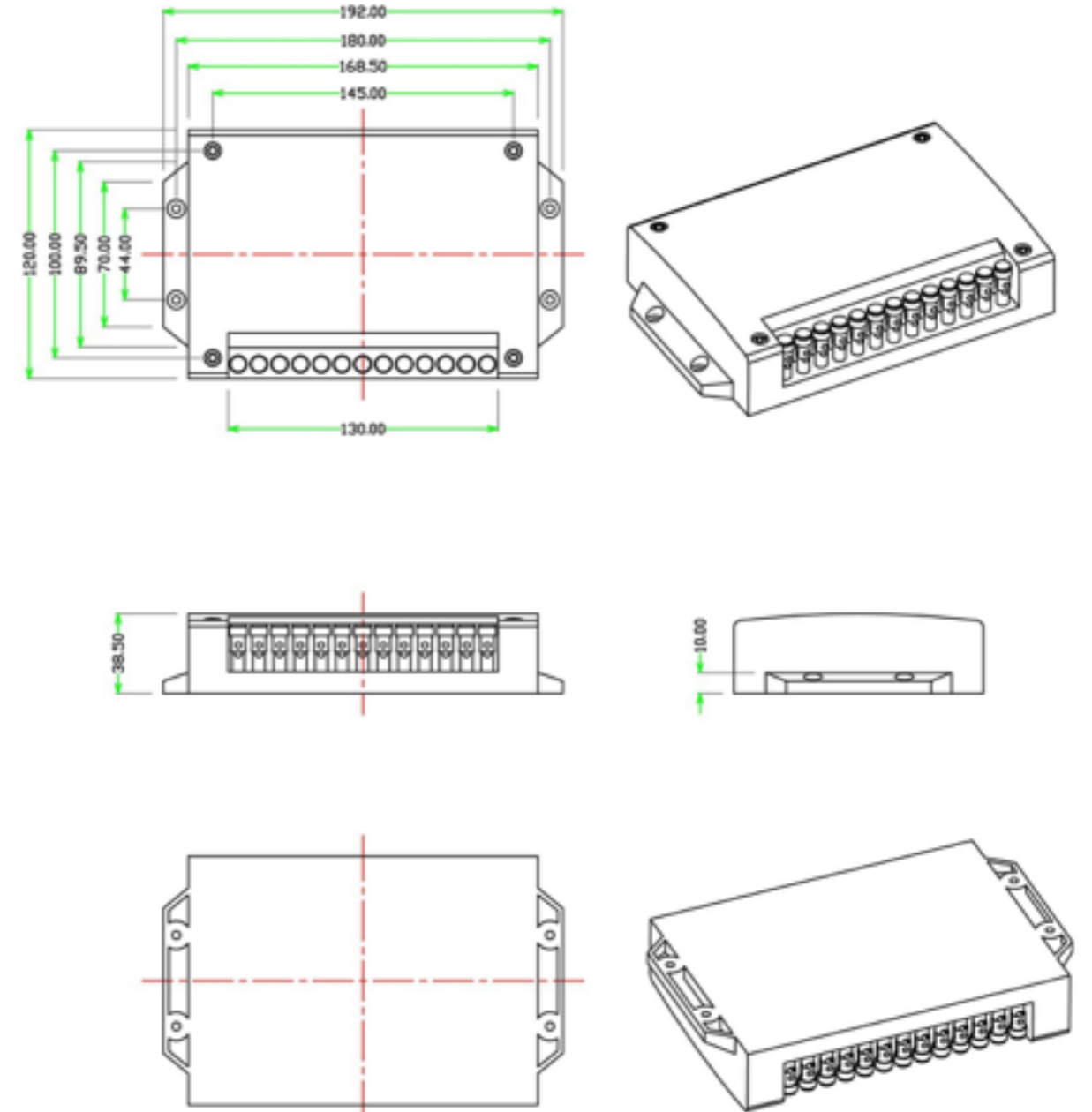

Legatia L1 Pro
Frequency Response Graph

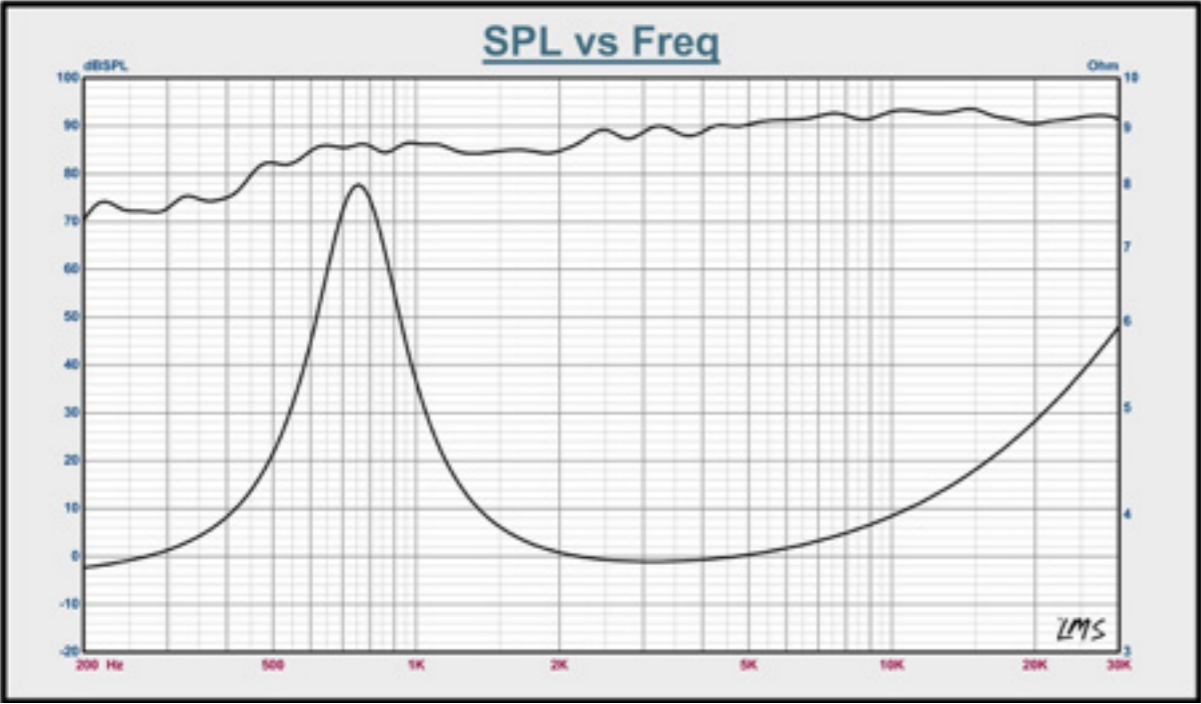

Legatia L3 Pro
Frequency Response Graph

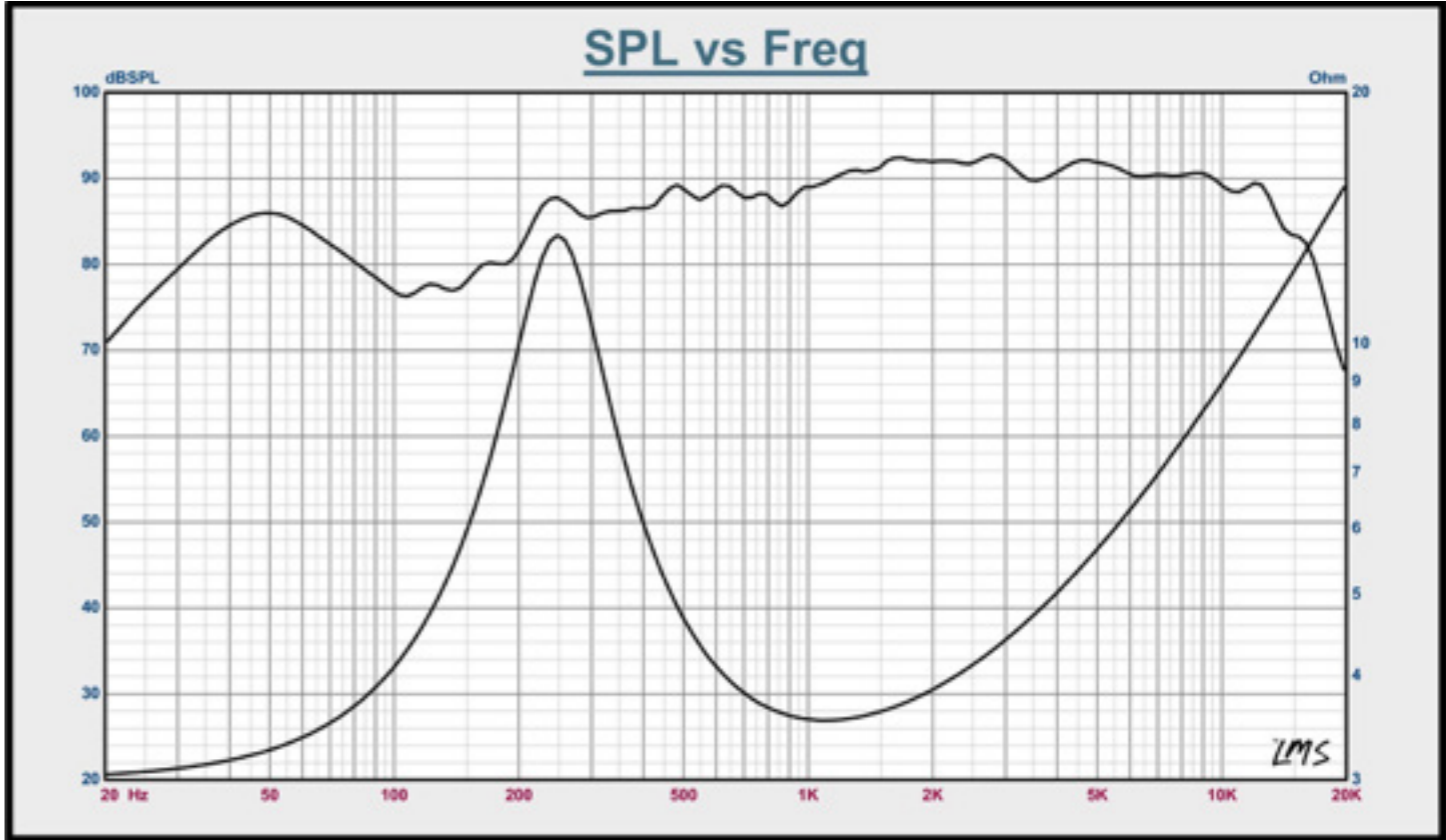

Legatia L2x Frequency Filter Plot

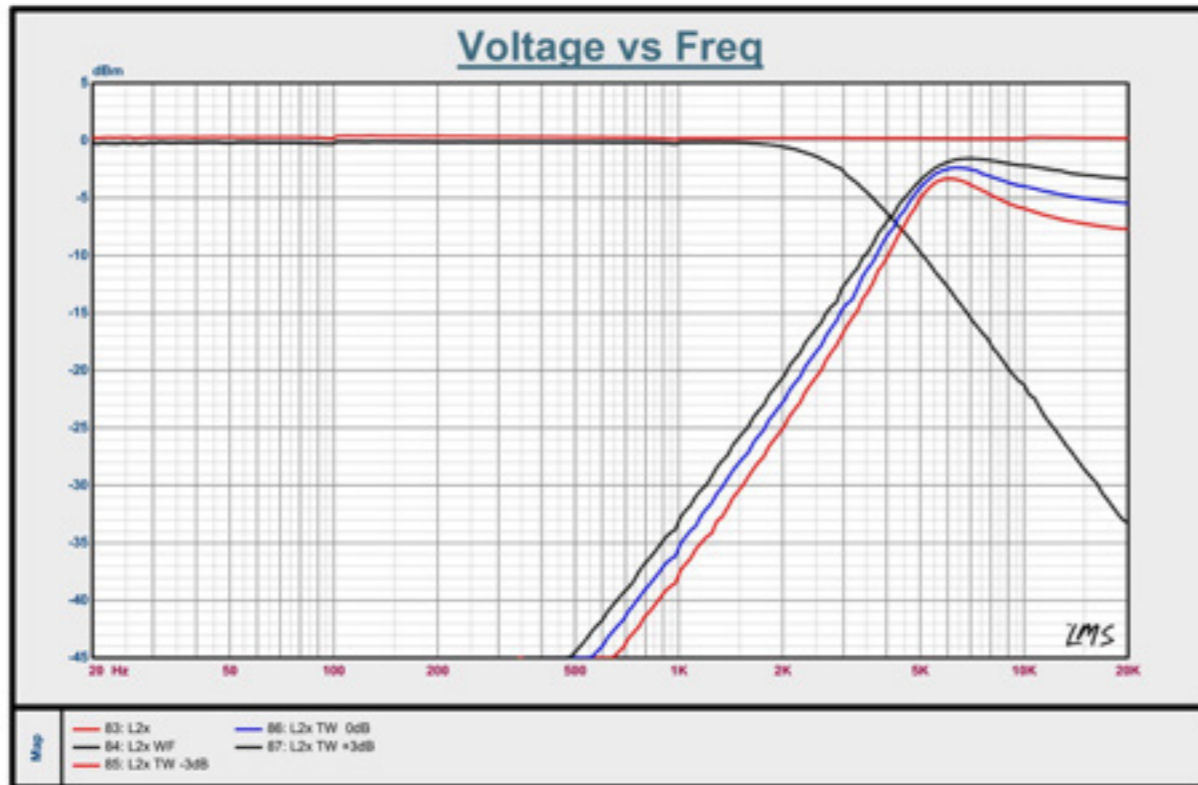

Legatia L3x Frequency Filter Plot

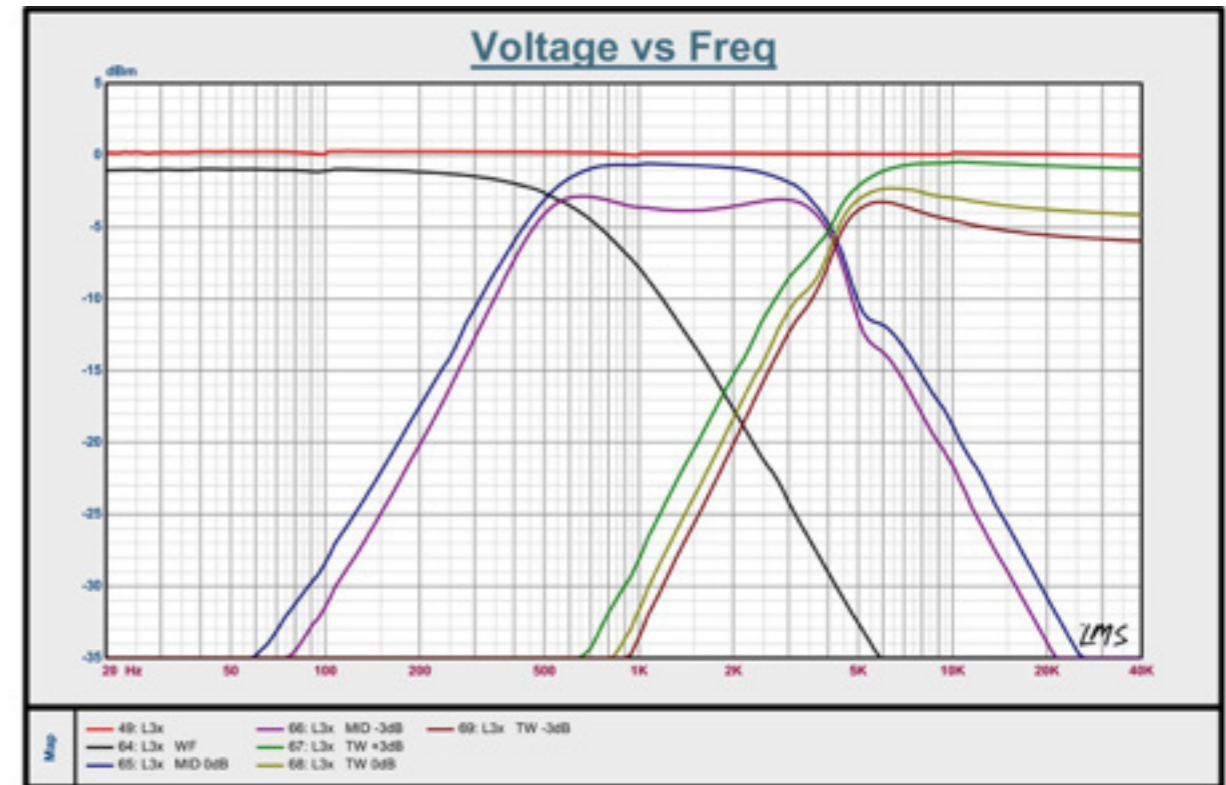

Advanced System Installation

Hybrid Audio Technologies has prepared a more advanced topical discussion of Legatia Pro installation techniques, concepts, and principals, where a little bit of additional installation work can net immense gains in overall sound quality.

There are certainly many things you can do to improve your mobile audio system, such as addition of amplification, a dedicated subwoofer system, higher-gauge speaker wire, and higher-end passive crossovers, and active crossovers. All of these things require an additional amount of monetary investment into your audio system, and may not net the immediate gains that other, more elementary installation items can net. The following discussion is pertinent to easy and cost-effective enhancements you can do for your audio system, particularly as it relates to the installation of Legatia Pro component speakers.

In any mobile audio system, the weakest link will always be the speaker systems, followed closely by installation techniques (sometimes its vice-versa). Since the Legatia Pro component speakers you have purchased has solved the first issue, the second issue, that being installation techniques, can see a significant improvement as well by understanding and incorporating some or all of the techniques in the following sections.

Lessons Learned

We like to call this our “Lessons Learned” section, where we expose some critical lessons that we have learned through thousands upon thousands of hours of trial and error:

Lesson One: Off-Axis Response

When a speaker system like the Legatia Pro is placed in an automotive environment, we hear the direct (shortest path) and reflected (longer path) sounds, such as resonances and reverberations. The two sounds are processed by the brain as one sound, and this influences our perception of height, width, and depth of soundstage, as well as rearward ambience. For this reason, the off-axis radiation pattern of any speaker in a vehicular environment has a significant influence on how natural the music sounds.

The lesson to learn here is that most mobile audio sound systems benefit greatly from having the front stage speakers at least partially “off-axis.” Off-axis means that the speakers are not pointing at you, but rather at some angle less than 90 degrees away from you.

Lesson Two: Equalization of Pathlength Differences

Quite possibly the most important functional consideration that a do-it-yourself enthusiast or professional installer should give to the Legatia Pro speaker placement is to optimize, as best as possible, pathlength differences (PLD's) in the vehicle. PLD's are defined mathematically as follows (this example assumes a right-hand drive vehicle---PLD's are always a positive number):

$$X - Y = Z$$

Where:

X = distance of the center of the left speaker from your left ear.

Y = distance of the center of the right speaker from your right ear.

Z = pathlength difference.

Applying this formula, assume that the distance of the left speaker from your left ear is 140cm, and the distance of the right speaker from your right ear is 100cm, the pathlength difference is 40cm.

Good stereo imaging is completely dependent on arrival times of the fundamental vocal frequencies. Differences as little as 10 microseconds can be detected by the brain. A PLD of 30 centimeters equates to the sound from the nearest channel arriving about 0.9 milliseconds earlier than the furthest channel. It is Hybrid Audio's opinion that the end-user should try to keep PLD's to less than 30 centimeters in a vehicle which is intended to have good imaging and staging character **from both seated positions**.

The best way to go about evaluating certain locations in your vehicle is, in general, to look for the potential locations as far forward and away from you as possible, but still with a general “line of sight” to the speakers (particularly the speaker on the far side of the vehicle). An easy way to test various potential locations is to hold a tape measure or other measurement device from the potential speaker mounting locations, and measure those locations with respect to your ears.

Reference the figure, below. In this scenario, three potential locations for the mounting of the Legatia Pro midrange driver are shown:

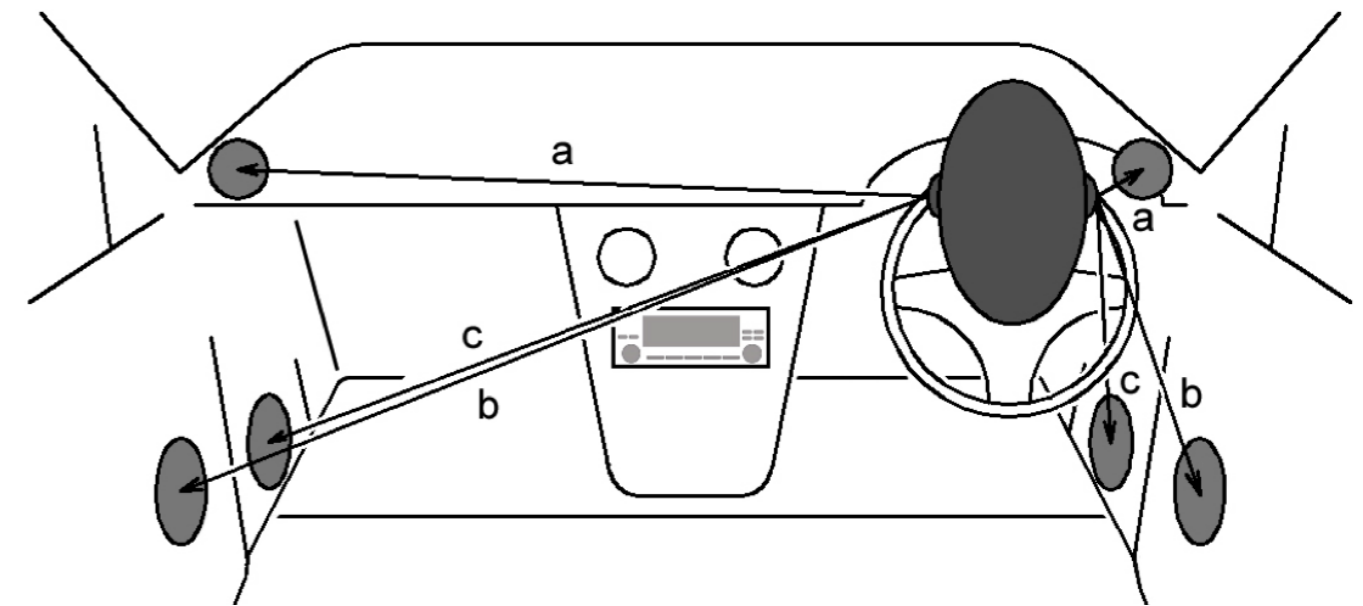

Lesson Two: Equalization of Pathlength Differences (Continued)

In scenario “a”, we show the installation of the Legatia Pro midrange in the dashboard or high in a door panel. As you can see from the diagram, the PLD’s between the left and right speakers are large, due to the proximity of the listener to the near-side speaker. While the mounting of primary drivers in the dashboard or a-pillars has become increasingly popular, this configuration will undoubtedly require both time and intensity domain equalization in most vehicles to ensure a good, focused center image, properly located in the center of the vehicle for **one seated position**.

There are, however, some rare exceptions, and you may actually find that the dashboard locations provide the best equalized PLD of the available mounting locations; this is very rare though – in our experience, less than one percent of vehicles on the market today have optimized dashboard speaker locations for the midbass drivers.

In scenario “b”, a typical door installation location is shown, and in many vehicles represents a good improvement in PLD’s from the dashboard, high in the door panel, and a-pillar location identified in scenario “a.” The door speaker installation scenario is the one detailed in the basic installation section at the beginning of this manual, and in most vehicles represents a satisfactory location to mount speakers; not ideal but satisfactory. The door speaker installation scenario will likely also require some amount of time and intensity equalization to ensure a centered image in most vehicles; this can be as simple as adjusting the balance control on your source unit, to more advanced ways of digital time and intensity manipulation.

The third and final potential mounting location as shown in this diagram (scenario “c”) represents a kick panel installation, where the midbass are placed far forward in the A-frame cavity of the kick panels, present in most vehicles. The kick panels are the small panel next to the throttle and brake pedals, down by your feet. While it is not immediately obvious looking at a two-dimensional drawing, in many cases the kick panel location affords the best equalization of pathlength differences for most vehicles. And the reason why this is a good choice for most vehicles is defined in the second full paragraph of Lesson Three, below.

The lesson to be learned here is that by taking a few moments to evaluate the potential mounting locations in your vehicle, in a very short period of time, you will be able to find the best location for your Legatia Pro midrange by determining the location with the smallest PLD.

Lesson Three: The Effect of HRTF, ITD, and IID

Head-related transfer function (HRTF), interaural intensity differences (IID), and interaural time delay (ITD) all play a key role in the optimum placement location for the Legatia Pro component speakers.

A sound wave approaching the eardrum from your chosen speaker location is shaped by interactions with the size and shape of your head, torso, and outer ear, resulting in the HRTF. More specifically, the HRTF is the ratio between the sound pressures of the wave at the eardrum, as compared to the sound pressure that would exist at the center of the head if the head were removed. In general, the sound arriving at the ear further from the source is attenuated and delayed relative to the sound arriving at the ear closer to the source. This generates an interaural intensity difference (IID) and an interaural time delay (ITD). As a sound approaches the head, the ratio of distances from the speaker location to the near and far ears increases, and the effects of head-shadowing are amplified, causing the IID to increase. The spectral shaping caused by the head and the shape of the outer ear may also change. The ITD, which results from the absolute difference in path length from the source to the ears, remains approximately constant as distance decreases. From this we learn:

- ITD is the dominant factor for frequencies below about 500 Hz;
- A combination of ITD and IID are dominant for frequencies between approximately 500 Hz and 2,000 Hz; and
- IID, in concert with HRTF, are dominant above about 2,000 Hz.

These are generalizations, and are subject to the size and shape of one’s head and torso, and size and shape of the outer ear (the folds and ridges of the ear), but in general, the above is a good guideline for establishing ITD, IID and HRTF thresholds for the human auditory system.

Because the Legatia Pro midrange’s ability to play into the sub-400 Hz range, an effect clearly dominated by ITD, up to and including frequencies exceeding 6,000 Hz, an effect clearly dominated by IID and HRTF, placement of this driver is extremely important. The driver should be placed as far forward as possible in the vehicle to optimize ITD. Lateral (forward to back) placement is much more important than horizontal placement (up and down). This is because of the brain’s ability to process sounds such as spectral envelope cues, and use a phenomenon known as the “precedence effect”; the brain can be easily “fooled” into thinking a sound stage is high with kick panel or floor-mounted speakers (a word to the wise: the best place to put a set of speakers is not always “up high”, as most vehicles do not offer an amicable location in the dashboard or a-pillars for good image placement for both seated passengers, especially in the critical frequencies sub-500 Hz). In addition to the time equalized placement of the drivers, the end-user must also consider that above approximately 2,000 Hz, intensity plays a key role in good sound staging and imaging. Therefore, the Legatia Pro midrange’s should be placed in an area where intensity differences can be equalized, either mechanically or electronically, to ensure good imaging and sound staging.

The lesson to be learned is that, like Lesson Two, the Legatia Pro midrange should be placed as far forward from your listening position as possible, and every effort should be made to optimize time and intensity domain characteristics of the installation.

Lesson Four: Point-Sourcing

The term “point-sourcing” is often used to describe the technique of having a single pair of speakers in an installation cover the majority of the critical middle band frequencies. In many installation scenarios, the Legatia Pro midrange could be considered a point-source speaker driver, because it has the ability to reproduce up to six octaves of tones. Point-sourcing, if done correctly, can lend itself to a variety of valuable attributes, including precise image definition and stable sound staging character. By applying Lessons 1-3 above, the Legatia Pro midrange can be used as a point-source driver to achieve excellent staging and imaging results.

The lesson to be learned here is that the Legatia Pro midrange, given its wide-bandwidth design, can faithfully reproduce as much as six octaves of tones, and would make a valuable addition to any sound system as a point-source driver for the spectrum comprising vocal imaging cues.

Lesson Five: Reference

One of the most important things to do before completing your Legatia Pro installation is to get a reference for your future listening tests. To really know what a snare drum sounds like, you must go and listen to one, in person, live and un-amplified. There is no substitute for the visceral impact and emotion of live music. Nothing else in life can touch your soul the way music does. Whether it's a 200-member orchestra, or a four-piece fusion band, nothing compares to the phenomenon of live music.

Take this as Hybrid Audio's official request: become a student of music and your mobile audio sound system will be better for it. We want nothing more than to know there are great sounding audio systems around the world using our products, and you'd make us all very proud if you became a student of music and learned its beauty and passion.

Advanced Installation of the Legatia Pro Component Speakers

Mounting Baffle Considerations

Now that we have revealed five of our most important “Lessons Learned”, we can now apply these lessons to the Legatia Pro installation. The first important matter is the physical installation of your Legatia Pro midrange, and more specifically with respect to improving the Legatia Pro midrange's mounting baffles. Most vehicles' factory mounting locations for speakers are less than ideal. In most cases, the OEM speaker mounting flanges are likely nothing more than flimsy extruded plastic, and provide no sonic benefit to your Legatia Pro installation.

The Legatia Pro drivers are high-performance midrange, and the plastic mounting baffles that come from the factory in virtually every vehicle will lead to buzzes, rattles, vibrations, and resonances, all of which negatively affect the Legatia Pro installation. In other vehicles, you may have attached the Legatia Pro midrange's directly to the door metal (hopefully with a layer or two of self-adhesive sound damping in between), but this is still not entirely ideal. In whatever scenario you have installed your Legatia Pro midrange, there are certain “tricks” and techniques that may be applied to get the most out of your Legatia Pro component set, specifically the midrange installation, as follows:

Mounting the baffle, sound damping, and “decoupling”

The mounting baffle or mounting location should either be secured extremely well to the vehicle's body, or completely isolated from the vehicle's chassis. The reasoning is that the speaker baffle panel will vibrate and will radiate sound. Even small vibrations can result in the baffle itself radiating more sound than the actual speaker at certain frequencies. The mounting baffle or mounting location should be damped with a layer of typical sound damping to reduce the Q of the baffle and lower its vibration resonance frequency below the range of the driver's frequency response. In many cases, using thicker baffle panel in concert with self-adhesive sound damping can also be advantageous, provided the rearward wave of the speaker has no obstructions created by the baffle itself. Finally, if possible, the speaker should be mechanically decoupled from the baffle. This can be something as simple as a layer of self-adhesive foam tape, to more exotic examples of decoupling, including rubberized rings or multiple-layer septum shielding.

Building solid mounting baffles

In many cases, it is advisable to mount your Legatia Pro midrange's in high-stiffness wood or high-density fiberglass (or wood treated with fiberglass resin). Hybrid Audio Technologies recommends the use of a solid hardwood, such as birch or oak, namely because these woods are stiff and help to dissipate resonance, and screws can be inserted and removed multiple times without stripping. Avoid Medium Density Fiberboard (MDF), particularly in wet environments like the door, as the MDF will act like a sponge with humidity and moisture, and not only that, the MDF is a dense, but not stiff type of wood, and the results may not be particularly noticeable if you use MDF. Once your baffle is built, it must be covered in one or two layers of a good-quality, brand name self-adhesive damping product; a solid wood mounting baffle with sound damping treatment will augment the Legatia Pro installation by eliminating resonances.

Advanced Installation of the Legatia Pro Component Speakers (Continued)

Mounting baffle dimensions

While building baffles is important, it is notable that mounting baffle size is equally important. All mounting baffles should be kept as small as possible with respect to the size of the speaker. The purpose of using a small baffle is to avoid the potential for low amplitude diffracted sound waves becoming summed with the incidental waves. A narrower baffle also becomes increasingly important as frequencies range into the Legatia Pro midrange's upper bandwidth, where the power response is more uniform and incident and reflected waves are indistinguishable. In practical terms, keep baffle dimensions small with respect to the size of the Legatia Pro midrange, chamfer or round sharp edges, flush-mount the speaker whenever possible, and use shallow, surface-mounted hardware (or ideally use the supplied knurled attachment nuts). Also, remove all unnecessary protrusions from the baffle surface.

Crossovers

One of the most fundamental and important considerations in the final tweaking of a car audio system is the set-up of the speaker's crossovers. The Legatia Pro drivers use fine cloth diaphragms that exhibit little if any cone breakup in its upper frequency bandwidth. However, it is still important to utilize crossovers, especially active crossover networks to suit the speaker system to the car's acoustic signature. It has been Hybrid Audio's philosophy to tune the speaker system to the vehicle's acoustic signature using just active crossovers, and only a very minor amount of equalization. Our very best world championship vehicles have always had one thing in common: creative use of active crossover filters and very minimal equalization. Use your crossovers to tune your car, and the equalizer to suit the vehicle's speaker response to your own tastes.

The first thing to remember is that every speaker exhibits some sort of a natural roll-off. This rolloff typically amounts to about 12 dB/octave, and needs to be taken into account, especially when designing passive crossover systems (this roll-off has been accounted for in the Legatia L2x and L3x designs). Simply adding a capacitor and inductor in series (6 dB/octave bandpass filter) to a Legatia Pro midrange driver does not necessarily mean that you'll see a phase coherent 6 dB/octave bandpass filter at its crosspoints. In fact, summing the effect of the driver's natural bandpass roll-off, you might actually be approaching a theoretical 18 dB/octave bandpass filter at certain frequencies. Not only this, but the speaker could potentially begin to exhibit significant intermodulation distortion as the cone becomes non-linear trying to reproduce the lowest octave of tones, not to mention irregular polar radiation patterns between the Legatia Pro midrange and the accompanying Legatia Pro tweeter.

Given the large uncertainty of low-order crossover systems, Hybrid Audio recommends the use of higher-order electronic crossovers so that fine tuning can be done electronically. The active network benefits from easy correction of different speaker sensitivities and equalizing not only the individual drivers but the combined response as well. Not having to account for the speaker's impedance verses frequency, as well as the passive device impedance and phase shift makes the active filter superior to most passive crossover networks, due to the fact that each and every aspect can be tailored to better suit the individual installation's requirements. However, we understand that in some cases that passive filters are required, and thus the reason why we have manufactured the Legatia L2x two-way and Legatia L3x three-way passive crossover systems. In our humble opinion, however, the ideal crossover system for most users, is an active one that takes into account the Legatia Pro driver location and its characteristics, in concert with the polar radiation patterns of other speakers involved, all the while balancing linear and non-linear distortion (non-linear harmonic distortion increases with sound pressure level or cone displacement, and thus, crossover frequency is critical and can be vehicle and user dependent).

As mentioned previously in "Lesson Three", imaging cues of near-field (within 3m) sources come from effectively two auditory methods: ITD and IID. ITD is the time it takes for sound to reach the far ear after reaching the near ear. Typical adult male heads have an ITD maximum of approximately 400 microseconds. IID is the measure of intensity difference of the far ear as compared to the near ear. ITD is typically used by the brain to localize low frequency sources below 500 Hz. IID is typically used by the brain to localize high frequency sources, above 2,000 Hz. HRTF is also used in conjunction with IID. Above approximately 4,000 Hz, the higher frequencies are attenuated by the head for the far side ear. A sound to your left will have a different spectral content for the left ear as compared to the right ear. The HRTF is unique for each individual (based upon shape and size of the head and torso) but typically occurs at around 4,000-5,000 Hz. HRTF will affect the IID at even higher frequencies, more so than simple average SPL. Above 6,000 Hz or so, the HRTF portion of IID becomes the dominant factor. The spoken word (human voice) comprises a fundamental frequency range of approximately 150 Hz to 6,000 Hz.

Taking the above into account, your desired crossover frequency for the Legatia Pro midrange should be one that allows the midrange to play as much of the audible spectrum of the spoken voice to ensure point-source delivery of the tones and pinpoint image definition. In many cases, this would be around 320-400 Hz for high pass, and around 6,000 Hz, or higher, for low pass. In all cases, the chosen crossover frequencies should be evaluated for sonic character, while balancing distortion and power compression at high amplitude levels.

Advanced Installation of the Legatia Pro Component Speakers (Continued)

Time Correction

It is our humble opinion that time correction should only be used in three different circumstances:

- 1) When the installer recognizes that a vehicle cannot image properly from both seated positions and it seems more plausible to make the vehicle stage and image well from only one seated position.
- 2) To counter the effects of group delay.
- 3) Time alignment between pairs of drivers.

Scenario 1

The first scenario is rather elementary. If a vehicle is too small to achieve equalized PLD's, it doesn't lend itself well to equalized PLD's, or the vehicle's owner doesn't wish to embark on physical reconstruction of the car to achieve optimized PLD's, it is a good use of time correction to make the vehicle image well from the single seated position. It should be noted that it is Hybrid Audio's opinion that it is always better to improve the car mechanically and attempt to fix mechanical problems with mechanical solutions, than it is use to electronics to fix mechanical problems. However, we realize that there is the occasion when there is little desire to try to mechanically optimize one's listening space, and electronic manipulation is desired. It is important to recognize that, given the fundamentals of ITD and IID discussed previously, time alignment is rendered virtually useless for frequencies above approximately 2,000 Hz.

Scenario 2

In the second scenario, the use of time correction is much more cognitive, and shows great promise for countering the effects of group delay. Group delay is impulse response over time. Group delay increases significantly at low frequencies, and is considerable in larger midbass and subwoofers. An excellent use of time correction would be to delay the smaller Legatia midranges and tweeters with respect to the larger midbass and subwoofers, so that the low frequency delay of these drivers is synchronized in the time domain with the output of the midrange and treble frequencies.

Scenario 3

The final scenario is time alignment between pairs of drivers. When employing multiple drivers in order to achieve a unified listening experience within a vehicle, it's usually a requirement to install the drivers at physically separated locations; for example, your midbass may be located in the doors, and the midrange and tweeter may be located in the dashboard or a-pillar. In order to compensate for this, you might choose to selectively delay certain speakers in the installation so that all of the tones reach your ears at the same time (note that as previously alluded to, time alignment of your tweeters would be rendered virtually useless).

Amplitude Equalization

An excellent use of today's dual-mono equalizers and advanced digital signal processing is the ability to equalize amplitude anomalies between speakers and sets of speakers installed in a vehicle. In a vehicular installation, the frequency response of drivers can sometimes be manipulated for the betterment of the system using independent left and right amplitude adjustment. Virtually any good car audio system can be made better with judicious use of a minor amount of equalization. And while equalization will not cure phasing anomalies in a car, usually the product of vehicular mechanics, they can certainly be helpful in fine-tuning the system to your own personal taste or in the quest for playback accuracy to the original musical composition.

One important consideration of amplitude equalization (also known in some circles as "amplitude alignment") is the ability to tune those frequencies above about 500 Hz that are not completely affected by time correction. The very best vehicles have some sort of amplitude equalization between the left and right speakers to account for IID and HRTF. After your Legatia Pro system is installed, you may wish to attempt some minor amplitude equalization between the left and right channels to achieve a more stable image that is not frequency dependent, or perhaps to improve image placement or stage coherency.

Advanced Installation of the Legatia Pro Component Speakers (Continued)

Acoustic Treatment

A considerable benefit can be made to any mobile audio system with the select placement of acoustic treatments. The purpose of using acoustic treatments is to reduce the amount of reflected energy in the hostile automotive environment, and hear more of the direct sound being emanated from the speaker. It is akin to the signal to noise (S/N) ratio in a piece of electronics, where the signal could be considered the direct energy coming from the speaker, and the noise could be considered the reflected waves off of nearby surfaces, such as windows, hard center consoles and door panels, windscreens, and etc. A word of warning though: there is a fine line between too little and too much acoustic treatment; just as some vehicles can benefit from some selectively applied treatments, there is a point where the vehicle can begin to approach “semi-anechoic” conditions, and lose its liveliness, which is not ideal. Reflections are all around us, and are a part of our day-to-day lives. It is our opinion that some lateral reflection is a good thing; it helps to establish stage boundaries, and gives the recoded playback and more visceral and “believable” sound.

The first principle to understand is that below 200 Hz, acoustic treatments are rendered virtually useless. It is Hybrid Audio’s assertion that only those frequencies above 200 Hz benefit from the use of treatments, given that a 200 Hz waveform is about 1.7 m long; 1.7 meters is less than or equal to most vehicle widths. This is also the frequency where we believe pure tones in the vehicle are going to be difficult, if not impossible to localize. Finally, most vehicles exhibit a Schroeder Frequency (Fs) between 50 at 125 Hz; the Fs (or cabin-gain frequency) is vehicle dependent, and is the frequency at which resonances become so tightly packed in frequency and space that the acoustical properties of the vehicle behave quite uniformly. (As an aside, one significant benefit of car audio sound systems is that frequencies below the lowest room resonance increase at a theoretical 12 dB/octave...it’s no wonder car audio systems have such great bass!)

Acoustic treatment can be very effective above 200 Hz, depending mostly on the polar radiation pattern of the speaker. In the case of the Legatia midbass, the polar radiation pattern is quite large at lower frequencies, with a narrowing of the radiation pattern (“beaming”) at frequencies into the treble bandwidth.

Should the Legatia midbass and/or midrange be placed in the kick panel locations, one may find that a notable improvement can be made by adding acoustical treatments, such as open-cell foam, into the underside of the dashboard. Likewise, should the midbass, midrange, and/or tweeter be placed up high on a-pillars, or in the dashboard, where comb filtering (reflective summation and cancellation off of a hard surface, such as a windscreen)

may become an issue, a dashboard “mat” or other soft furnishing may be a noticeable improvement. It will require trial and error to get it right, but the learning is in the experimentation!

Advanced Installation Conclusions

Sadly, there are no rules in mobile audio, only several hypothesis and theorems that seem to work for most vehicles. Your vehicle may be different, and defy everything we know, and everything written in this manual. You may find that getting that rich, detailed sound that you crave may require some experimentation and a lot of work to make it right. Or you might be fortunate to have a vehicle that sounds excellent with minimal work. Have patience and work through the issues; the result will be a rewarding musical experience in your vehicle! Just remember, it is critical to get a reference, as detailed in Lesson 5. Go out and become a student of music and audio, learn, and improve your audio system one step at a time. The journey is exciting and rewarding!

What we have included above is only a very brief primer to the world of high-end mobile audio systems. We invite you to read more by going to our website.

Legatia Pro Component Speakers Warranty

Hybrid Audio Technologies extends a limited one year warranty to the original purchaser when self-installed, and three years warranty when installed by a certified Hybrid Audio Technologies dealer (United States only), and hereby certifies that this product will be free from defects in materials and workmanship under normal and proper use for one year from the date of purchase.

Hybrid Audio Technologies' responsibility under this warranty is limited to replacing or repairing, at Hybrid Audio Technologies' option, products or parts determined by Hybrid Audio Technologies to be defective either in materials, or workmanship. To attain warranty service, the customer must deliver the product or the defective part(s), appropriately packed with proof of purchase date, to an authorized Hybrid Audio Technologies dealer. In the event that a direct return from a consumer is required, the consumer must obtain from Hybrid Audio Technologies a return authorization number, and ship the defective product directly to Hybrid Audio Technologies. All shipping expenses are the customer's responsibility. If the product has been updated or superseded, a replacement will be made with a current model of the same quality and function. Warranty of the replacement parts is limited to 90 days or the unexpired portion of the warranty

period of the product on which the parts are being used, whichever is longer.

This warranty does not cover any defects or costs caused by: (1) modification, alteration, repair or service of this product by any persons or company other than Hybrid Audio Technologies; (2) physical abuse to, overload of, or misuse of, the product or operation thereof in a manner inconsistent with the use indicated in the instructions; (3) any use of the product other than that for which it was intended; or (4) shipment of the product to Hybrid Audio Technologies for service. This warranty does not cover labor costs.

Hybrid Audio Technologies is not liable for any special incidental or consequential damages, including, but not limited to, personal injury, property damage, damage to or loss of equipment, loss of profits or revenue, costs of renting or buying replacements and/or any other additional expenses, even if Hybrid Audio Technologies has been informed of the prospect of such damages. Any express warranty not provided herein, and any remedy which other than the warranty contained herein might arise by inference or operation of law, is hereby excluded and disclaimed including the implied warranties of merchantability and of the fitness for a particular purpose.

Thank You!

Hybrid Audio Technologies is delighted that you have chosen a Legatia Pro Component Speakers for your high-end mobile audio sound system. We are convinced that a great product offering, backed up with unsurpassed customer service and technical support will advance the Hybrid Audio Technologies namesake in the coming years. We are pleased that you have joined us in our "new generation of in-car audio."

If there is anything we can do to help you get the most out of your Legatia Pro installation, please do not hesitate to email us: support@hybrid-audio.com, by phone: 770.888.8200, or by visiting us at: hybrid-audio.com



1240 Oak Industrial Lane
Cumming Georgia 30041
United States

(T) +1 770 888 8200
(F) +1 888 886 4605
hybrid-audio.com